

ENVIRONMENTAL PRODUCT DECLARATION

IN ACCORDANCE WITH EN 15804+A2 & ISO 14025 / ISO 21930

Multi-purpose spirally wound PE pipe
Pipelife Finland Oy



EPD HUB, HUB-1681

Publishing date 28 June 2024, last updated on 28 June 2024, valid until 28 June 2029.

GENERAL INFORMATION

MANUFACTURER

Manufacturer	Pipelife Finland Oy
Address	Kiviharjunlenkki 1 E, 90220 Oulu, Finland
Contact details	asiakaspalvelu@pipelife.fi
Website	https://www.pipelife.fi/

EPD STANDARDS, SCOPE AND VERIFICATION

Program operator	EPD Hub, hub@epdhub.com
Reference standard	EN 15804+A2:2019 and ISO 14025
PCR	EPD Hub Core PCR version 1.1, 5 Dec 2023
Sector	Construction product
Category of EPD	Third party verified EPD
Parent EPD number	-
Scope of the EPD	Cradle to gate with options, A4-A5, and modules C1-C4, D
EPD author	Riikka Vaara
EPD verification	Independent verification of this EPD and data, according to ISO 14025: <input type="checkbox"/> Internal verification <input checked="" type="checkbox"/> External verification
EPD verifier	Magaly González Vázquez, as an authorized verifier acting for EPD Hub Limited

The manufacturer has the sole ownership, liability, and responsibility for the EPD. EPDs within the same product category but from different programs may not be comparable. EPDs of construction products may not be comparable if they do not comply with EN 15804 and if they are not compared in a building context.

PRODUCT

Product name	Multi-purpose spirally wound PE pipe
Additional labels	-
Product reference	-
Place of production	Talokaivo Vantaa, Finland
Period for data	Calendar year 2023
Averaging in EPD	No averaging
Variation in GWP-fossil for A1-A3	- %

ENVIRONMENTAL DATA SUMMARY

Declared unit	1 kg of pipe
Declared unit mass	1 kg
GWP-fossil, A1-A3 (kgCO ₂ e)	2,20E+00
GWP-total, A1-A3 (kgCO ₂ e)	2,20E+00
Secondary material, inputs (%)	0.29
Secondary material, outputs (%)	80
Total energy use, A1-A3 (kWh)	9.6
Net fresh water use, A1-A3 (m ³)	0.03

PRODUCT AND MANUFACTURER

ABOUT THE MANUFACTURER

Pipelife Finland Oy is one of the leading providers of Plastic construction solutions in Finland. The product range consists of plastic pipe, tank and chamber solutions, rainwater management, oil and sand separation solutions, wastewater treatment solutions, and solutions for energy and data network construction, as well as electric installations. Pipelife Finland solutions are used in construction in infrastructure, housing and industrial applications. Pipelife Finland Oy employs about 250 employees in Finland. The company is part of leading global construction solution provider Wienerberger AG and its piping solution division WPS. It operates globally in 25 countries and provides piping solutions based on plastic and ceramic materials. We are certified according to EN ISO 9001 Quality Management system and EN ISO 14001 Environmental Management system.

PRODUCT DESCRIPTION

Pipelife Jenga™ - PE spirally wound pipe is a lightweight and versatile spiral seam pipe suitable for many applications. The structurally strong pipe reduces installation costs and facilitates handling on site. Pipelife Jenga™ is manufactured with ring stiffness classes SN2, SN4, and SN8. Pipelife Jenga™ is delivered as standard in 6 m lengths. On request, spiral seam pipe is also available according to the customer's needs up to 10 m. Pipelife Jenga™ is a versatile pipe system for many different uses in new construction and renovation. Pipelife Jenga™ is suitable for building storm water systems, culvert pipes, wells, and tanks. In addition, it is easy to build special applications from Jenga for industrial needs. Lightweight Pipelife Jenga is easy to handle. Easy handling speeds up installation work and reduces the need for heavy crane equipment, reducing installation costs. Pipelife Jenga™ withstands mechanical and chemical stress. It does not dissolve in the liquid to be conducted, rot, crumble, or corrode due to chemical or electrical reactions. Pipelife Jenga™ is made of recyclable PE plastic, so excess installation pieces can be returned to recycling points.

SFS EN 13476 Plastics piping systems for non-pressure underground drainage and sewerage (mechanical properties)

Further information can be found at <https://www.pipelife.fi/>.

PRODUCT RAW MATERIAL MAIN COMPOSITION

Raw material category	Amount, mass- %	Material origin
Metals	0	-
Minerals	0	-
Fossil materials	100	EU
Bio-based materials	0	-

BIOGENIC CARBON CONTENT

Product's biogenic carbon content at the factory gate

Biogenic carbon content in product, kg C	0
Biogenic carbon content in packaging, kg C	0

FUNCTIONAL UNIT AND SERVICE LIFE

Declared unit	1 kg of pipe
Mass per declared unit	1 kg
Functional unit	-
Reference service life	-

SUBSTANCES, REACH - VERY HIGH CONCERN

The product does not contain any REACH SVHC substances in amounts greater than 0,1 % (1000 ppm).

PRODUCT LIFE-CYCLE

SYSTEM BOUNDARY

This EPD covers the life-cycle modules listed in the following table.

Product stage			Assembly stage		Use stage							End of life stage				Beyond the system boundaries		
A1	A2	A3	A4	A5	B1	B2	B3	B4	B5	B6	B7	C1	C2	C3	C4	D		
x	x	x	x	x	MND	MND	MND	MND	MND	MND	MND	x	x	x	x	x		
Raw materials	Transport	Manufacturing	Transport	Assembly	Use	Maintenance	Repair	Replacement	Refurbishment	Operational energy use	Operational water use	Deconstr./demol.	Transport	Waste processing	Disposal	Reuse	Recovery	Recycling

Modules not declared = MND. Modules not relevant = MNR.

MANUFACTURING AND PACKAGING (A1-A3)

The environmental impacts considered for the product stage cover the manufacturing of raw materials used in the production as well as packaging materials and other ancillary materials. Also, fuels used by machines, and handling of waste formed in the production processes at the manufacturing facilities are included in this stage. The study also considers the material losses occurring during the manufacturing processes as well as losses during electricity transmission.

The environmental impacts considered for the product stage cover the manufacturing of raw materials used in the production as well as packaging materials and other ancillary materials. Also, fuels used by machines, and handling of waste formed in the production processes at the manufacturing facilities are included in this stage.

The study also considers the material losses occurring during the manufacturing processes as well as losses during electricity transmission.

MANUFACTURING MATERIALS (A1)

The first module includes extraction and production of raw materials used in manufacturing process, mainly polyethylene granulates, as well as additives used in small amounts.

TRANSPORT FOR MANUFACTURING MATERIALS (A2)

Transport distances of materials to manufacturing site was modelled taking account location of suppliers and transportation routes. Raw materials are transported by lorry and by boat.

MANUFACTURING PROCESS (A3)

The production method is a pipe extrusion. The different stages are:

MATERIAL CONVEYING

The raw material is delivered by container and unloaded into silos at the product manufacturing site.

EXTRUSION (MELTING AND PROCESSING OF MATERIAL)

The extruder converts plastic raw material into a continuous tubular form by squeezing it through an annular nozzle.

COOLING

The melted pipe passes through sizing or calibration benches (which adjust the dimensions of the pipe) into a vacuum cooling tank, which cools the pipe to its shape. There are usually two other cooling tanks to cool the pipe.

PRINTING

The laser stamping machine marks pipes according to the used material, pipe size, diameter, length and produced batch number.

WINDING

Profile winding around adjustable steel drum, which defines pipe diameter. At the beginning of winding profiles are being welded together by extruding PE-seam between profiles.

CUTTING

The pipes are cut to the required length. The length of the pipes is usually 6 meter.

DISPATCH

After the final quality check, the products are sent to the ordered destination.

TRANSPORT AND INSTALLATION (A4-A5)

Transportation impacts occurred from final products delivery to construction site (A4) cover fuel direct exhaust emissions, environmental impacts of fuel production, as well as related infrastructure emissions.

Transportation impacts occurred from final products delivery to construction site (A4) cover fuel direct exhaust emissions, environmental impacts of fuel production, as well as related infrastructure emissions.

The average transport distance from the production plant to the building site is assumed to be 150 km, and the transport method is assumed to be a lorry. Transport does not cause losses, because products are packaged properly. During transportation there is not product or packaging loss.

PRODUCT USE AND MAINTENANCE (B1-B7)

This EPD does not cover the use phase.

Air, soil, and water impacts during the use phase have not been studied.

PRODUCT END OF LIFE (C1-C4, D)

Since the consumption of energy and natural resources is negligible for disassembling the end-of-life product, the impacts of demolition are assumed to be zero (C1). The end-of-life product is assumed to be sent to the closest facilities by lorry, and the journey is assumed to be 50 km (C2). It is estimated that there is no mass loss during the use of the product, therefore the end-of-life product is assumed to have the same weight as the declared product. After ca 50 years of service life (TEPPFA, 2018) all end-of-life product is assumed to be collected from the demolition site. Transportation distance to the waste-handling facility is estimated as 50 km and the transportation method is assumed to be lorry, which is the most common (C2). It is assumed that 80% of the end-of-life product is recycled and 20% is incinerated. The assumption is based on recycling info, environmental industries YTP ry, Municipal waste management companies reports and TEPPHA report (C3, C4). Due to the recycling and incineration potential of Polyethylene, the end-of-life product is converted into recycled PE, while energy and heat are produced from its incineration (D).

FLOW DIAGRAM

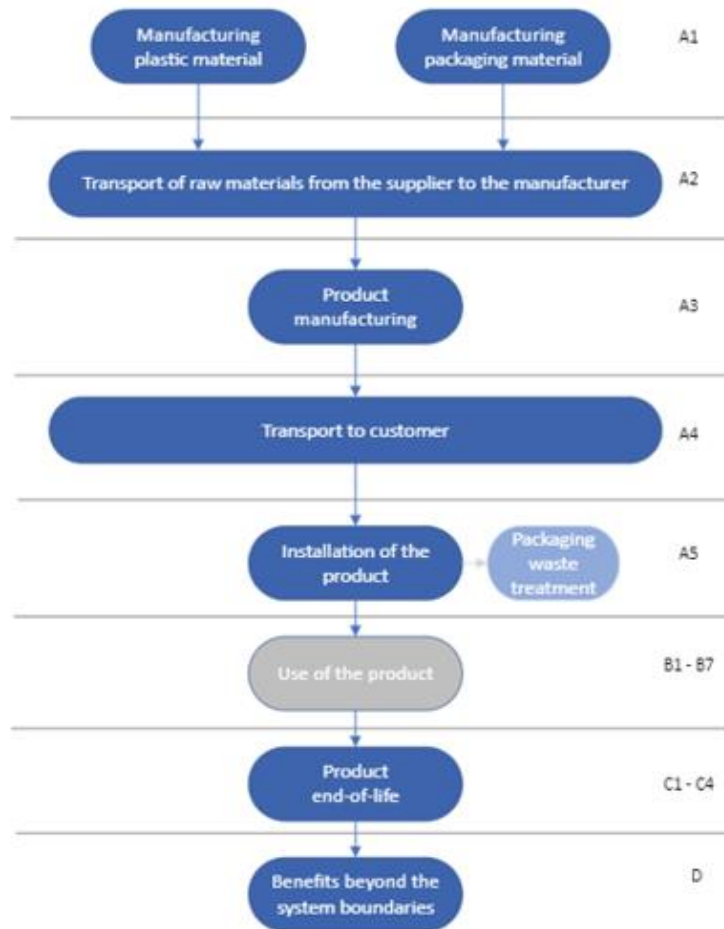

MANUFACTURING PROCESS (A1-A3)

Manufacturing process

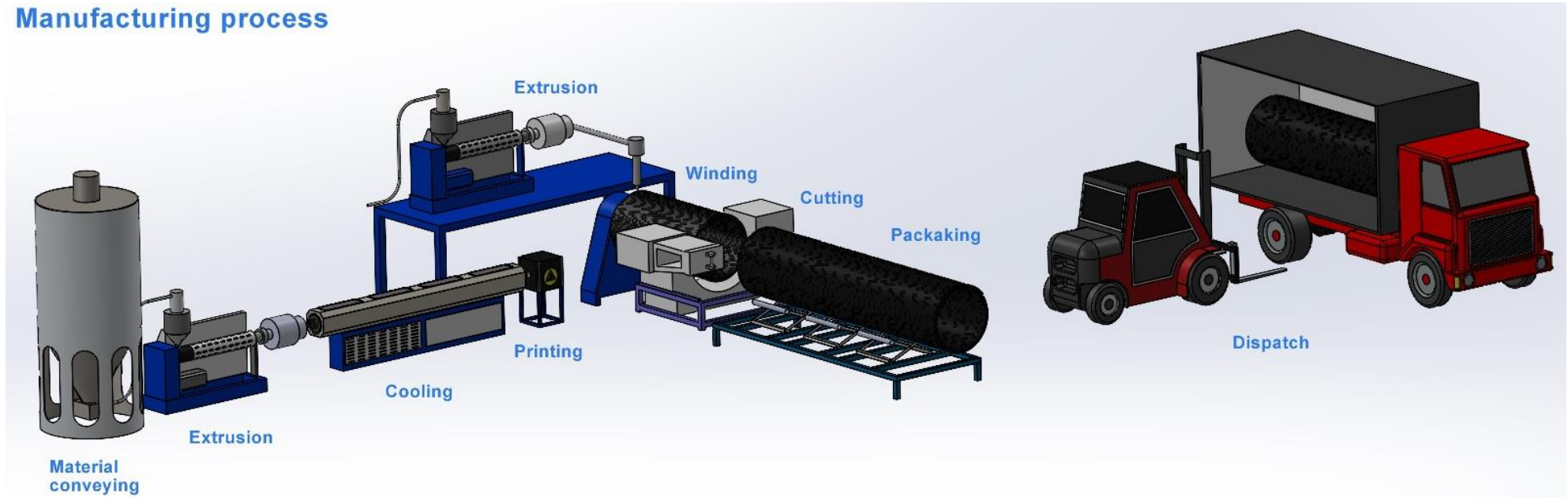

LIFE-CYCLE ASSESSMENT

CUT-OFF CRITERIA

The study does not exclude any modules or processes which are stated mandatory in the reference standard and the applied PCR. The study does not exclude any hazardous materials or substances. The study includes all major raw material and energy consumption. All inputs and outputs of the unit processes, for which data is available for, are included in the calculation. There is no neglected unit process more than 1% of total mass or energy flows. The module specific total neglected input and output flows also do not exceed 5% of energy usage or mass.

ALLOCATION, ESTIMATES AND ASSUMPTIONS

Allocation is required if some material, energy, and waste data cannot be measured separately for the product under investigation. All allocations are done as per the reference standards and the applied PCR. In this study, allocation has been done in the following ways:

Data type	Allocation
Raw materials	No allocation
Packaging materials	No allocation
Ancillary materials	No applicable
Manufacturing energy and waste	Allocated by mass or volume

AVERAGES AND VARIABILITY

Type of average	No averaging
Averaging method	No applicable
Variation in GWP-fossil for A1-A3	- %

This EPD is product and factory specific and does not contain average calculations.

LCA SOFTWARE AND BIBLIOGRAPHY

This EPD has been created using One Click LCA EPD Generator. The LCA and EPD have been prepared according to the reference standards and ISO 14040/14044. The EPD Generator uses Ecoinvent v3.8, Plastics Europe, Federal LCA Commons and One Click LCA databases as sources of environmental data.

ENVIRONMENTAL IMPACT DATA

CORE ENVIRONMENTAL IMPACT INDICATORS – EN 15804+A2, PEF

Impact category	Unit	A1	A2	A3	A1-A3	A4	A5	B1	B2	B3	B4	B5	B6	B7	C1	C2	C3	C4	D
GWP – total ¹⁾	kg CO ₂ e	1,99E+00	1,91E-01	1,32E-02	2,20E+00	1,36E-02	0,00E+00	MND	MND	MND	MND	MND	MND	MND	MNR	4,69E-03	7,39E-01	0,00E+00	-1,96E+00
GWP – fossil	kg CO ₂ e	1,99E+00	1,90E-01	1,32E-02	2,20E+00	1,36E-02	0,00E+00	MND	MND	MND	MND	MND	MND	MND	MNR	4,69E-03	7,39E-01	0,00E+00	-1,99E+00
GWP – biogenic	kg CO ₂ e	0,00E+00	0,00E+00	0,00E+00	0,00E+00	0,00E+00	0,00E+00	MND	MND	MND	MND	MND	MND	MND	MNR	0,00E+00	0,00E+00	0,00E+00	3,72E-02
GWP – LULUC	kg CO ₂ e	6,00E-04	7,03E-05	1,27E-05	6,83E-04	4,89E-06	0,00E+00	MND	MND	MND	MND	MND	MND	MND	MNR	1,73E-06	8,35E-05	0,00E+00	-7,43E-04
Ozone depletion pot.	kg CFC ₁₁ e	4,27E-08	4,38E-08	6,58E-10	8,72E-08	3,25E-09	0,00E+00	MND	MND	MND	MND	MND	MND	MND	MNR	1,08E-09	3,22E-09	0,00E+00	-4,41E-08
Acidification potential	mol H ⁺ e	7,07E-03	8,07E-04	8,26E-05	7,96E-03	5,68E-05	0,00E+00	MND	MND	MND	MND	MND	MND	MND	MNR	1,99E-05	2,98E-04	0,00E+00	-9,21E-03
EP-freshwater ²⁾	kg Pe	3,05E-05	1,56E-06	5,59E-07	3,26E-05	9,32E-08	0,00E+00	MND	MND	MND	MND	MND	MND	MND	MNR	3,84E-08	1,80E-06	0,00E+00	-4,17E-05
EP-marine	kg Ne	1,23E-03	2,40E-04	1,47E-05	1,48E-03	1,72E-05	0,00E+00	MND	MND	MND	MND	MND	MND	MND	MNR	5,90E-06	1,01E-04	0,00E+00	-1,34E-03
EP-terrestrial	mol Ne	1,34E-02	2,64E-03	1,45E-04	1,62E-02	1,90E-04	0,00E+00	MND	MND	MND	MND	MND	MND	MND	MNR	6,51E-05	1,07E-03	0,00E+00	-1,57E-02
POCP (“smog”) ³⁾	kg NMVOCe	6,62E-03	8,46E-04	5,40E-05	7,52E-03	6,10E-05	0,00E+00	MND	MND	MND	MND	MND	MND	MND	MNR	2,08E-05	3,01E-04	0,00E+00	-6,62E-03
ADP-minerals & metals ⁴⁾	kg Sbe	1,35E-05	4,47E-07	6,94E-07	1,46E-05	3,19E-08	0,00E+00	MND	MND	MND	MND	MND	MND	MND	MNR	1,10E-08	8,03E-07	0,00E+00	-9,79E-06
ADP-fossil resources	MJ	6,99E+01	2,86E+00	1,53E-01	7,29E+01	2,08E-01	0,00E+00	MND	MND	MND	MND	MND	MND	MND	MNR	7,05E-02	4,54E-01	0,00E+00	-5,95E+01
Water use ⁵⁾	m ³ e depr.	9,48E-01	1,28E-02	7,14E-03	9,67E-01	9,62E-04	0,00E+00	MND	MND	MND	MND	MND	MND	MND	MNR	3,15E-04	3,48E-02	0,00E+00	-7,42E-01

1) GWP = Global Warming Potential; 2) EP = Eutrophication potential. Required characterisation method and data are in kg P-eq. Multiply by 3,07 to get PO₄e; 3) POCP = Photochemical ozone formation; 4) ADP = Abiotic depletion potential; 5) EN 15804+A2 disclaimer for Abiotic depletion and Water use and optional indicators except Particulate matter and Ionizing radiation, human health. The results of these environmental impact indicators shall be used with care as the uncertainties on these results are high or as there is limited experience with the indicator.

ADDITIONAL (OPTIONAL) ENVIRONMENTAL IMPACT INDICATORS – EN 15804+A2, PEF

Impact category	Unit	A1	A2	A3	A1-A3	A4	A5	B1	B2	B3	B4	B5	B6	B7	C1	C2	C3	C4	D
Particulate matter	Incidence	7,06E-08	2,20E-08	1,18E-09	9,38E-08	1,60E-09	0,00E+00	MND	MND	MND	MND	MND	MND	MND	MNR	5,41E-10	6,32E-09	0,00E+00	-8,51E-08
Ionizing radiation ⁶⁾	kBq U235e	1,32E-01	1,36E-02	7,21E-04	1,46E-01	1,07E-03	0,00E+00	MND	MND	MND	MND	MND	MND	MND	MNR	3,36E-04	4,38E-03	0,00E+00	-1,46E-01
Ecotoxicity (freshwater)	CTUe	1,09E+01	2,57E+00	5,14E-01	1,40E+01	1,73E-01	0,00E+00	MND	MND	MND	MND	MND	MND	MND	MNR	6,34E-02	1,33E+00	0,00E+00	-2,46E+01
Human toxicity, cancer	CTUh	5,95E-10	6,32E-11	1,03E-10	7,62E-10	4,57E-12	0,00E+00	MND	MND	MND	MND	MND	MND	MND	MNR	1,56E-12	2,02E-10	0,00E+00	-5,91E-10
Human tox. non-cancer	CTUh	1,28E-08	2,55E-09	6,31E-10	1,60E-08	1,83E-10	0,00E+00	MND	MND	MND	MND	MND	MND	MND	MNR	6,27E-11	2,28E-09	0,00E+00	-1,39E-08
SQP ⁷⁾	-	1,84E+00	3,30E+00	4,43E-01	5,58E+00	2,43E-01	0,00E+00	MND	MND	MND	MND	MND	MND	MND	MNR	8,12E-02	7,83E-01	0,00E+00	-4,77E+00

6) EN 15804+A2 disclaimer for ionizing radiation, human health. This impact category deals mainly with the eventual impact of low dose ionizing radiation on human health of the nuclear fuel cycle. It does not consider effects due to possible nuclear accidents, occupational exposure nor due to radioactive waste disposal in underground facilities. Potential ionizing radiation from the soil, from radon and from some construction materials is also not measured by this indicator; 7) SQP = Land use related impacts/soil quality.

USE OF NATURAL RESOURCES

Impact category	Unit	A1	A2	A3	A1-A3	A4	A5	B1	B2	B3	B4	B5	B6	B7	C1	C2	C3	C4	D
Renew. PER as energy ⁸⁾	MJ	1,18E+00	3,22E-02	2,92E+00	4,13E+00	2,70E-03	0,00E+00	MND	MND	MND	MND	MND	MND	MND	MNR	7,94E-04	4,87E-02	0,00E+00	-1,53E+00
Renew. PER as material	MJ	0,00E+00	0,00E+00	0,00E+00	0,00E+00	0,00E+00	0,00E+00	MND	MND	MND	MND	MND	MND	MND	MNR	0,00E+00	0,00E+00	0,00E+00	0,00E+00
Total use of renew. PER	MJ	1,18E+00	3,22E-02	2,92E+00	4,13E+00	2,70E-03	0,00E+00	MND	MND	MND	MND	MND	MND	MND	MNR	7,94E-04	4,87E-02	0,00E+00	-1,53E+00
Non-re. PER as energy	MJ	2,74E+01	2,86E+00	1,53E-01	3,04E+01	2,08E-01	0,00E+00	MND	MND	MND	MND	MND	MND	MND	MNR	7,05E-02	4,54E-01	0,00E+00	-2,56E+01
Non-re. PER as material	MJ	4,25E+01	0,00E+00	0,00E+00	4,25E+01	0,00E+00	0,00E+00	MND	MND	MND	MND	MND	MND	MND	MNR	0,00E+00	-2,12E+01	-2,12E+01	3,74E+01
Total use of non-re. PER	MJ	6,99E+01	2,86E+00	1,53E-01	7,29E+01	2,08E-01	0,00E+00	MND	MND	MND	MND	MND	MND	MND	MNR	7,05E-02	-2,08E+01	-2,12E+01	1,18E+01
Secondary materials	kg	2,93E-03	7,94E-04	1,25E-03	4,97E-03	5,87E-05	0,00E+00	MND	MND	MND	MND	MND	MND	MND	MNR	1,96E-05	2,73E-03	0,00E+00	8,48E-01
Renew. secondary fuels	MJ	2,68E-05	8,02E-06	5,15E-06	4,00E-05	5,18E-07	0,00E+00	MND	MND	MND	MND	MND	MND	MND	MNR	1,97E-07	2,20E-05	0,00E+00	-5,65E-06
Non-ren. secondary fuels	MJ	0,00E+00	0,00E+00	0,00E+00	0,00E+00	0,00E+00	0,00E+00	MND	MND	MND	MND	MND	MND	MND	MNR	0,00E+00	0,00E+00	0,00E+00	0,00E+00
Use of net fresh water	m ³	2,45E-02	3,71E-04	1,61E-04	2,50E-02	2,76E-05	0,00E+00	MND	MND	MND	MND	MND	MND	MND	MNR	9,13E-06	4,84E-04	0,00E+00	-2,16E-02

8) PER = Primary energy resources.

END OF LIFE – WASTE

Impact category	Unit	A1	A2	A3	A1-A3	A4	A5	B1	B2	B3	B4	B5	B6	B7	C1	C2	C3	C4	D
Hazardous waste	kg	4,64E-02	3,79E-03	4,57E-03	5,48E-02	2,23E-04	0,00E+00	MND	MND	MND	MND	MND	MND	MND	MNR	9,34E-05	8,62E-03	0,00E+00	-8,59E-02
Non-hazardous waste	kg	1,30E+00	6,23E-02	2,45E-02	1,39E+00	3,89E-03	0,00E+00	MND	MND	MND	MND	MND	MND	MND	MNR	1,54E-03	3,25E-01	0,00E+00	-2,35E+00
Radioactive waste	kg	4,15E-05	1,91E-05	3,31E-07	6,09E-05	1,44E-06	0,00E+00	MND	MND	MND	MND	MND	MND	MND	MNR	4,71E-07	1,81E-06	0,00E+00	-4,57E-05

END OF LIFE – OUTPUT FLOWS

Impact category	Unit	A1	A2	A3	A1-A3	A4	A5	B1	B2	B3	B4	B5	B6	B7	C1	C2	C3	C4	D
Components for re-use	kg	0,00E+00	0,00E+00	0,00E+00	0,00E+00	0,00E+00	0,00E+00	MND	MND	MND	MND	MND	MND	MND	MNR	0,00E+00	0,00E+00	0,00E+00	0,00E+00
Materials for recycling	kg	0,00E+00	0,00E+00	0,00E+00	0,00E+00	0,00E+00	0,00E+00	MND	MND	MND	MND	MND	MND	MND	MNR	0,00E+00	8,00E-01	0,00E+00	0,00E+00
Materials for energy rec	kg	0,00E+00	0,00E+00	0,00E+00	0,00E+00	0,00E+00	0,00E+00	MND	MND	MND	MND	MND	MND	MND	MNR	0,00E+00	0,00E+00	0,00E+00	0,00E+00
Exported energy	MJ	0,00E+00	0,00E+00	0,00E+00	0,00E+00	0,00E+00	0,00E+00	MND	MND	MND	MND	MND	MND	MND	MNR	0,00E+00	6,82E+00	0,00E+00	0,00E+00

ENVIRONMENTAL IMPACTS – EN 15804+A1, CML / ISO 21930

Impact category	Unit	A1	A2	A3	A1-A3	A4	A5	B1	B2	B3	B4	B5	B6	B7	C1	C2	C3	C4	D
Global Warming Pot.	kg CO ₂ e	1,89E+00	1,89E-01	1,28E-02	2,09E+00	1,35E-02	0,00E+00	MND	MND	MND	MND	MND	MND	MND	MNR	4,64E-03	7,37E-01	0,00E+00	-1,87E+00
Ozone depletion Pot.	kg CFC ₁₁ e	3,70E-08	3,47E-08	5,95E-10	7,24E-08	2,57E-09	0,00E+00	MND	MND	MND	MND	MND	MND	MND	MNR	8,55E-10	2,79E-09	0,00E+00	-3,66E-08
Acidification	kg SO ₂ e	5,90E-03	6,27E-04	6,90E-05	6,60E-03	4,40E-05	0,00E+00	MND	MND	MND	MND	MND	MND	MND	MNR	1,54E-05	2,26E-04	0,00E+00	-7,75E-03
Eutrophication	kg PO ₄ ³ e	1,50E-03	1,43E-04	2,75E-05	1,67E-03	9,84E-06	0,00E+00	MND	MND	MND	MND	MND	MND	MND	MNR	3,52E-06	4,97E-04	0,00E+00	-1,58E-03
POCP (“smog”)	kg C ₂ H ₄ e	6,01E-04	2,45E-05	4,80E-06	6,31E-04	1,73E-06	0,00E+00	MND	MND	MND	MND	MND	MND	MND	MNR	6,03E-07	1,46E-05	0,00E+00	-6,00E-04
ADP-elements	kg Sbe	1,35E-05	4,32E-07	6,88E-07	1,46E-05	3,11E-08	0,00E+00	MND	MND	MND	MND	MND	MND	MND	MNR	1,07E-08	7,94E-07	0,00E+00	-9,74E-06
ADP-fossil	MJ	6,99E+01	2,86E+00	1,53E-01	7,29E+01	2,08E-01	0,00E+00	MND	MND	MND	MND	MND	MND	MND	MNR	7,05E-02	4,53E-01	0,00E+00	-5,94E+01

VERIFICATION STATEMENT

VERIFICATION PROCESS FOR THIS EPD

This EPD has been verified in accordance with ISO 14025 by an independent, third-party verifier by reviewing results, documents and compliance with reference standard, ISO 14025 and ISO 14040/14044, following the process and checklists of the program operator for:

- This Environmental Product Declaration
- The Life-Cycle Assessment used in this EPD
- The digital background data for this EPD

Why does verification transparency matter? [Read more online](#)

This EPD has been generated by One Click LCA EPD generator, which has been verified and approved by the EPD Hub.

THIRD-PARTY VERIFICATION STATEMENT

I hereby confirm that, following detailed examination, I have not established any relevant deviations by the studied Environmental Product Declaration (EPD), its LCA and project report, in terms of the data collected and used in the LCA calculations, the way the LCA-based calculations have been carried out, the presentation of environmental data in the EPD, and other additional environmental information, as present with respect to the procedural and methodological requirements in ISO 14025:2010 and reference standard.

I confirm that the company-specific data has been examined as regards plausibility and consistency; the declaration owner is responsible for its factual integrity and legal compliance.

I confirm that I have sufficient knowledge and experience of construction products, this specific product category, the construction industry, relevant standards, and the geographical area of the EPD to carry out this verification.

I confirm my independence in my role as verifier; I have not been involved in the execution of the LCA or in the development of the declaration and have no conflicts of interest regarding this verification.

Magaly González Vázquez, as an authorized verifier acting for EPD Hub Limited
28.06.2024

